

EXCLUSIVE: WATER-COOLED VICTORY COMING SOON!

American Cruiser Maker Readies a Liquid-Cooled Lineup With Four Top-Secret Designs Revealed.

Written by Motorcyclist on March 28 2014 3:39 PM

Recommend (11) | Tags (10) | 4 | 13 | 27

MOTOR CYCLIST



WORDS: Ben Purvis

Victory Motorcycles have been out of the limelight lately—outshined by parent company Polaris’ intense focus reviving its sister brand, Indian—but now Victory is set to come back with a vengeance by launching a new range of high-performance, liquid-cooled cruisers.

We’ve uncovered drawings of no fewer than four top-secret designs for new Victory models, all with water-cooled V-twin engines. With Indian assuming the role of classic American cruiser to compete with Harley-Davidson, Victory is now free to carve out a new niche as a maker of modern, high-performance V-twins—think of something to compete with Ducati’s Diavel, rather than Harley’s Road King. In an interview appearing in the October 2013 issue of Motorcycles, Steve Menneto, told us that Victory would be retooled “to focus on performance and innovation as core brand values.” These drawings are clear evidence that this change is underway.



The most complete of the four new designs is a composite by Polaris Design Chief Greg Brew, along with fellow designers Richard Christoph and Ray Frigard (colorized by MC Art Director Kathleen Conner). This is the most traditional of the four bikes shown, a classic solo-seat bobber with conventional fenders and tank, and a short subframe that doubles as a mounting point for the twin rear shocks. At the center sits what appears to be a large-displacement, liquid-cooled, DOHC V-twin engine. Unlike the other three designs, this bike has its drive belt on the left hand side and unique wheels and suspension.

The remaining trio features what appears to be a quite different engine, still a water-cooled, DOHC V-twin but with a more stylized external appearance and a transmission with the drive belt located on the right-hand side. These also share the same wheels and swingarm, all of which appear to be taken straight from the existing Victory Judge model. The implication here is that these concepts are part of an internal design contest, all using the Judge chassis as a template for the appearance of the new water-cooled engine. Likely one of these will be selected to progress towards production.



Victory1: Styled by Polaris Senior Industrial Designer Richard Christoph, this look is distinguished by large radiator shrouds that enclose much of the front cylinder. An angular rear fender appears to incorporate a modular seat, its shape echoing the style line leaning the engine compartment.



Victory2: The work of Salvador Gonzales, another Polaris designer, this aggressive design has a distinctive hooded headlight and a sharp-ended pillion seat that juts out and above the rear fender. The low-mounted radiator is separate from the main body, leaving more of the engine exposed.



Victory3: The work of former Tesla and Volvo car designer Ryan Black-Macken, the last of the Judge-based designs is more flowing and futuristic than the others, with a smooth, integrated look connecting the tank to the tail and an elongated headlight fairing that completely hides the lens in profile.

Any speculation regarding engine capacity or performance potential would be little more than guesswork at the moment, but expect Polaris to answer those questions for us sooner than later. Menneto told us last year, “It’s about time the Victory had a new powertrain.”

Categories: News, Victory

Related Motorcyclist Magazine Posts



2015 Victory Gunner | First Look



BMW HP4 In The House



Indian Motorcycle Celebration At Daytona Bike Week 2014



2014 Victory Line Offers More Flash For Less Cash



2014 Pricing Announced By BMW



American International Motorcycle Expo Tickets On Sale Now

COMMENTS:

Leave a Reply

Name (required)
 Email (required, but never shared)
 Web



[Home](#) » [Up To Speed](#) » [EXCLUSIVE: Water-Cooled Victory Coming Soon!](#) » V 1

V 1

[Photo](#)

[Back to EXCLUSIVE: Water-Cooled Victory Coming Soon!](#)

Recommend Tweet

Viewing photo 1 of 4

[Next](#)

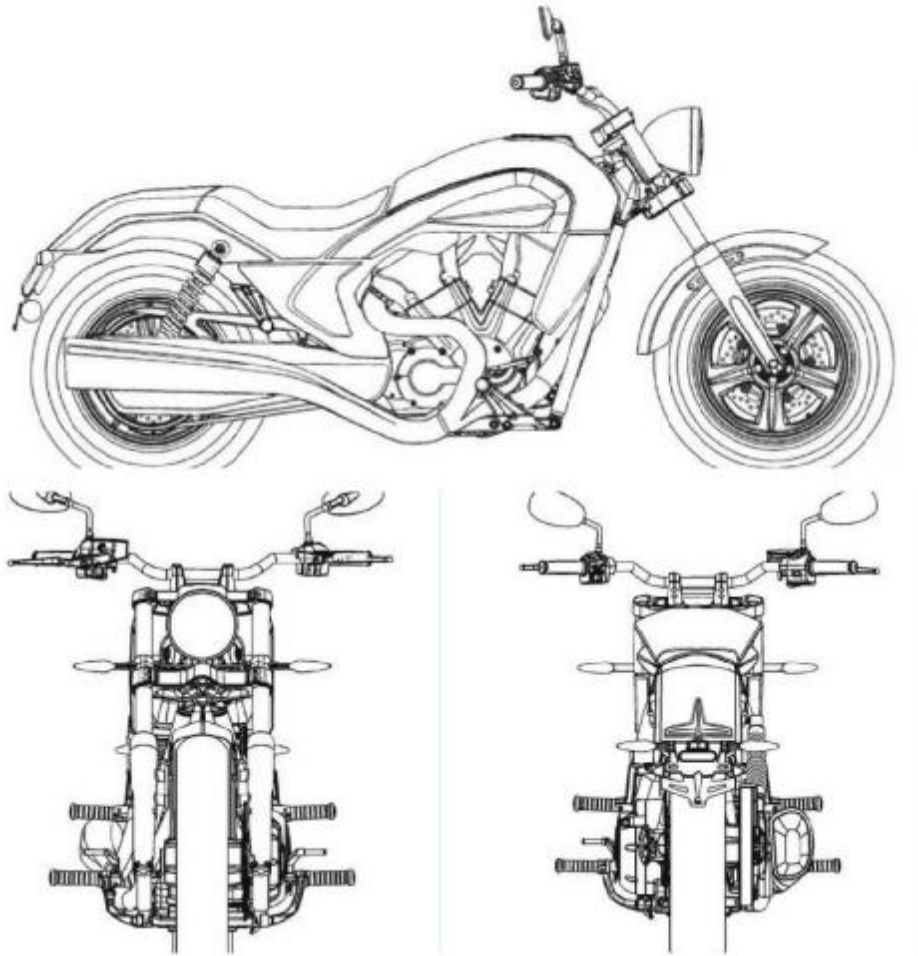

Victory1: Styled by Polaris Senior Industrial Designer Richard Christoph, this look is distinguished by large radiator shrouds that enclose much of the front cylinder. An angular rear fender appears to incorporate a modular seat, its shape echoing the style line framing the engine compartment. ([Full Image](#))

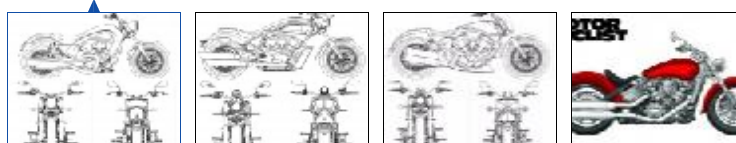

Sponsored Links

We Buy Any Bike in the UK
Selling Your Bike? Contact Us To Sell Your Bike Now! Free Collection
www.webuyanybike.com

Used Cars
Search 1,000's of Select Approved Used Cars & Find Dealer Details
citroen.co.uk/Used-Cars

Motorcycles Accessories
Expert Service For Better Buys. Central London Motorbikes.
centralbikes.co.uk

-70% Off Shoei® Helmets
48 Hrs Free Delivery & Returns Buy Online Now!

[Home](#) » [Up To Speed](#) » [EXCLUSIVE: Water-Cooled Victory Coming Soon!](#) » [V 2](#)

V 2

[Privacy](#)

[Back to EXCLUSIVE: Water-Cooled Victory Coming Soon!](#)

Recommend Tweet

Viewing photo 2 of 4

[Previous](#)

[Next](#)

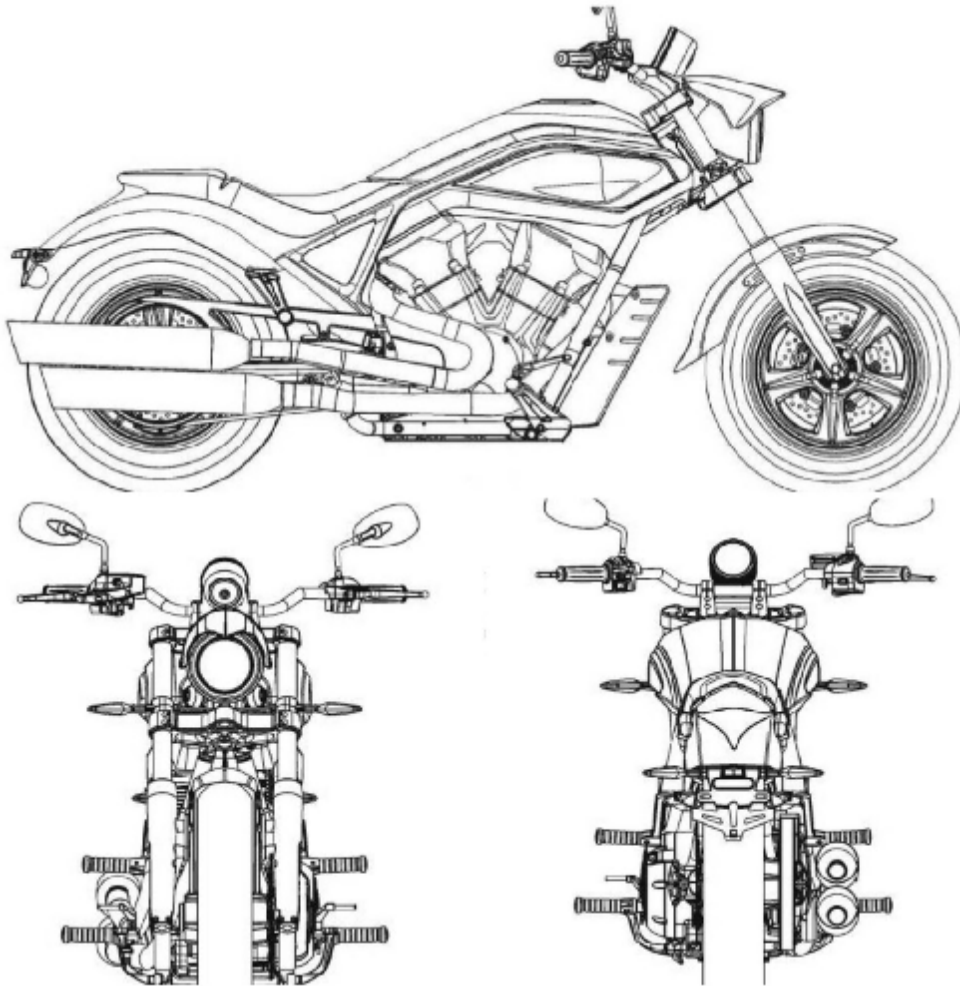

Victory2: The work of Salvador Gonzales, another Polaris designer, this aggressive design has a distinctive hooded headlight and a sharp-ended pillion seat that juts out and above the rear fender. The low-mounted radiator is separate from the main body, leaving more of the engine exposed. ([Full Image](#))

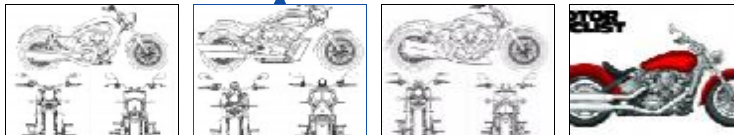

Sponsored Links

We Buy Any Bike in the UK
 Selling Your Bike? Contact Us To Sell Your Bike Now! Free Collection
www.webuyanbike.com

Genuine Triumph Clothing
 Motorcycle Jackets, Gloves Boots.. Established UK Company since 1935
www.worldoftriumph.com

Motorcycles Accessories
 Expert Service For Better Buys. Central London Motorbikes.
centralbikes.co.uk

Your Chariot Hearse Trike
 A Final Good-bye in Style for Funerals with a Difference

[Home](#) » [Up To Speed](#) » [EXCLUSIVE: Water-Cooled Victory Coming Soon!](#) » [V 3](#)

V 3

[Back to EXCLUSIVE: Water-Cooled Victory Coming Soon!](#)

Recommend

Twitter

Google+

4

Viewing photo 3 of 4

[Previous](#)

[Next](#)

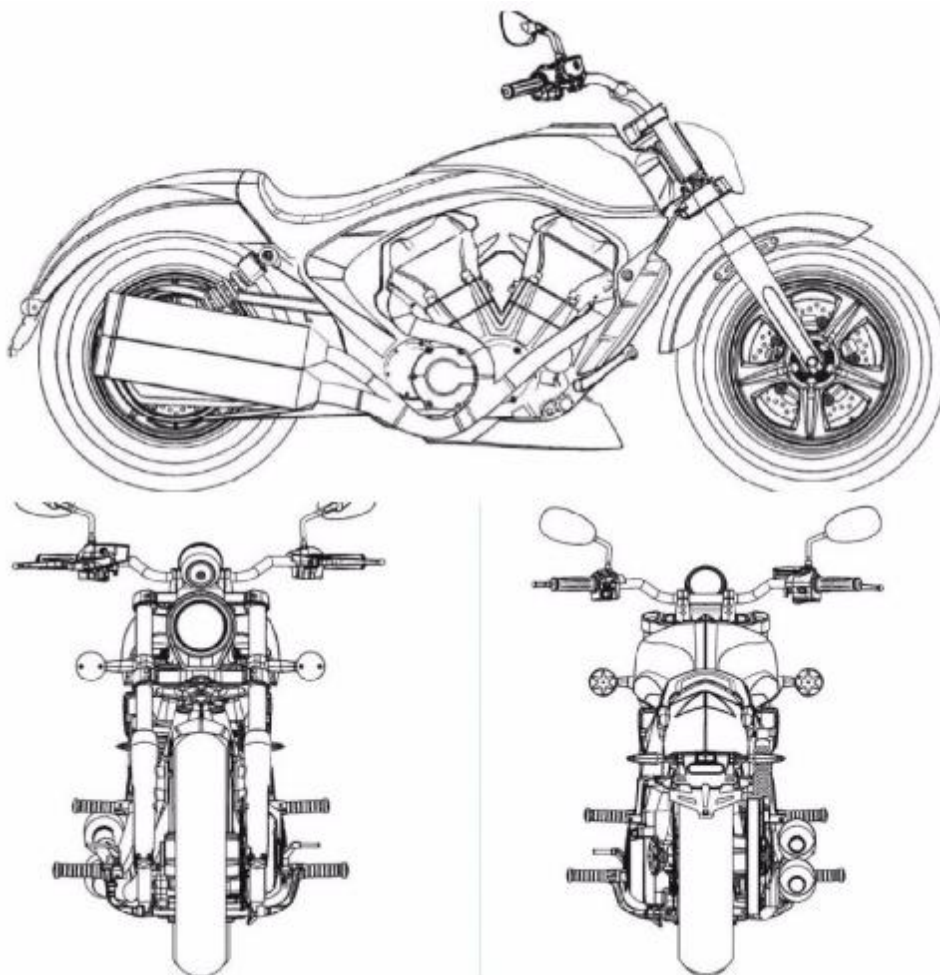

Victory3: The work of former Tesla and Volvo car designer Ryan Black-Macken, the last of the Judge-based designs is more flowing and futuristic than the others, with a smooth, integrated look connecting the tank to the tail and an elongated headlight fairing that completely hides the lens in profile. ([Full Image](#))

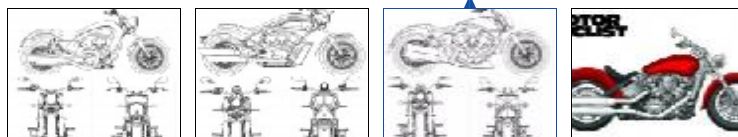

AVENGE
ENZ Design Series

Mini Beast Horns XR Series

Flag Mounts

Pro Pad Inc.
Premium Motorcycle Products

Sponsored Links

Cylinder Liners & Sleeves
Large Catalogue Plus Specials Call or Email For A Free Quotation.
www.westwoodcylinderliners.co.uk

Motorcycle tours Spain
Fantastic roads & tracks for real motorcycle riders
www.isabena.eu/en

Sell Your Harley Davidson
Free instant online valuation. Free Collection, Sell Your Harley today.
www.webuyanybike.com/HarleyDavidson

Insurance Claim Disputes
Marie-Claire di Mambro - Insurance Claims Expert



Home » [Up To Speed](#) » [EXCLUSIVE: Water-Cooled Victory Coming Soon!](#) » Victory_1_KC-1 MC

Victory_1_KC-1 MC

Close

[Back to EXCLUSIVE: Water-Cooled Victory Coming Soon!](#)

Tweet 0 +1 0

Viewing photo 4 of 4

Previous

MOTOR CYCLIST



The most complete of the four new designs is a composite by Polaris Design Chief Greg Brew, along with fellow designers Richard Christoph and Ray Frigard (colorized by MC Art Director Kathleen Conner). ([Full Image](#))

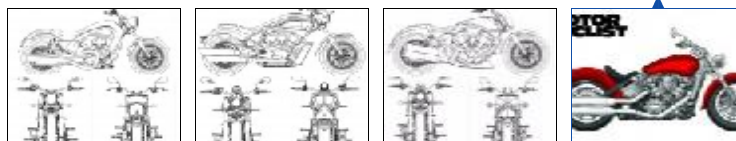

Sponsored Links

We Buy Any Bike in the UK
Selling Your Bike? Contact Us To Sell Your Bike Now! Free Collection
www.webuyanybike.com

Police Motorcycles Sale
Up To 70% Off Police Motorcycles Police Motorcycles. Compare
police.idealprice.co.uk

Local Motorbike Gear
Expert Service For Better Buys. Central London Motorbikes.
centralbikes.co.uk